

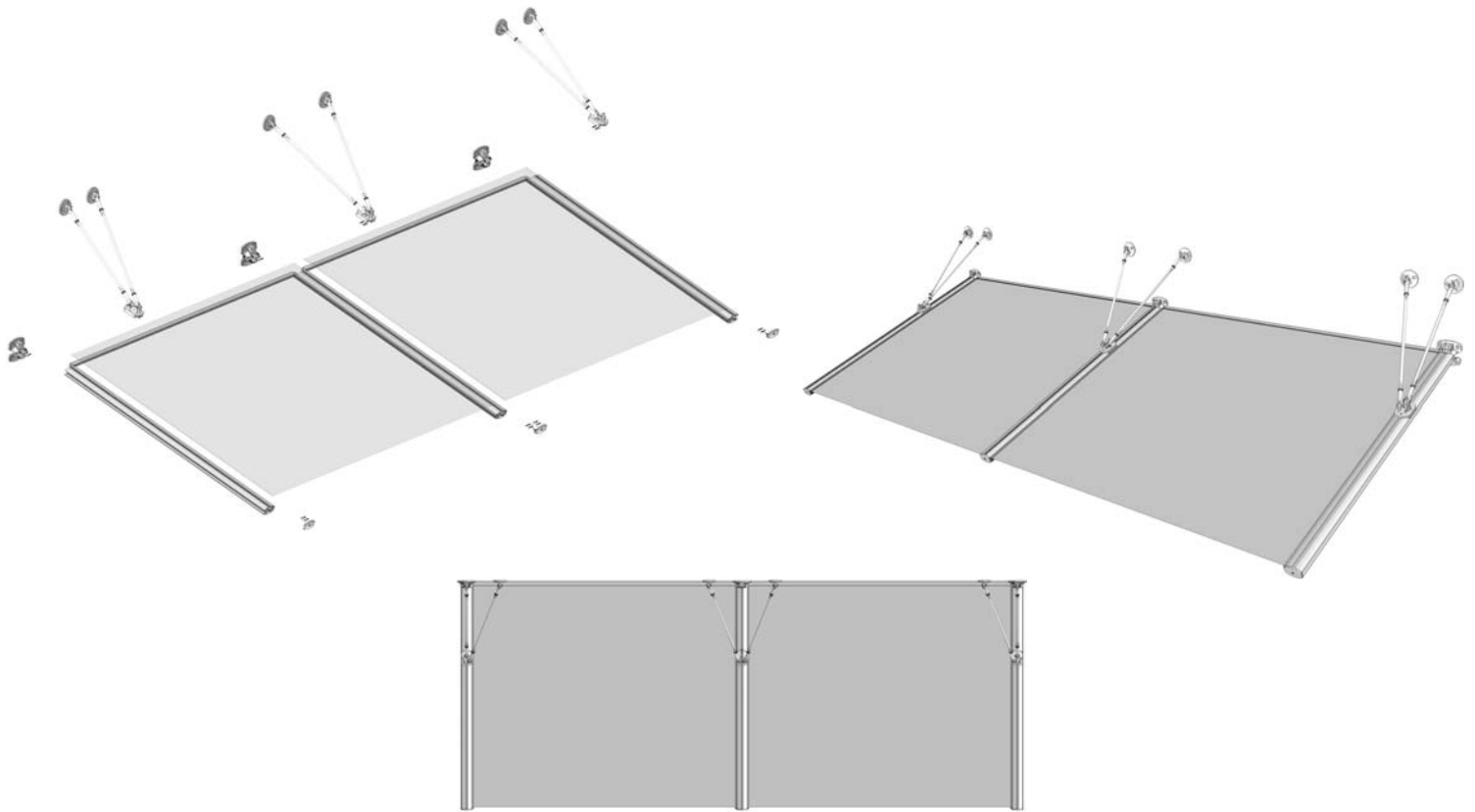

# PANAMA

Shelter Awning / Marquise

  
**Gaviota Simbac**  
SMART AWNINGS AND ROLLING SHUTTERS



**USE RECOMMENDATIONS**  
**RECOMMANDATIONS D'UTILISATION**

Length between poles, <b>A</b> <i>Longueur entre mâts A</i>	3 m maximum <i>Maximum 3 m</i>
Poles length, <b>B</b> <i>Longueur des mâts B</i>	2,5 m maximum <i>Maximum 2,5 m</i>
Distance tensor suport to pole, <b>C</b> <i>Distance fixation mât C</i>	0,7 m maximum <i>Maximum 0,7 m</i>

↓ **Cutting Adjustments / Mesures à couper**

**Drainage / Rejeteau**

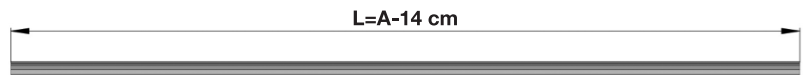

**Fabric / Toile**

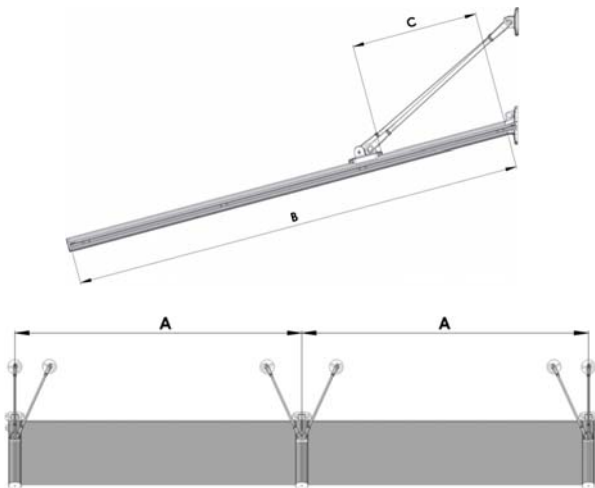
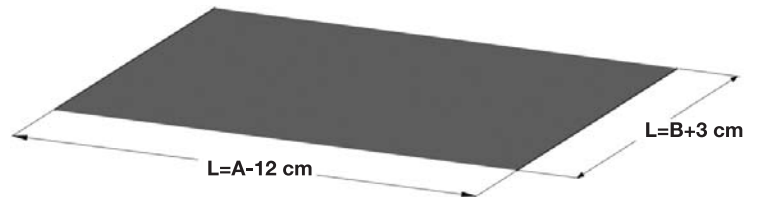

**Gaviota Simbac**  
STORES ET VOILETS ROULANTS INTELLIGENTS

GAVIOTA SIMBAC, S.L.

Autovia Alicante A-31. Km. 196 • 03630 SAX (Alicante) ESPAÑA / SPAIN

Tel. +34 966 474 200 • Fax +34 966 475 680

International Dept.: +34 966 968 276 • Fax +34 966 968 075

comercial@gaviotasimbac.com • export@gaviotasimbac.com

www.gaviotasimbac.com

